

Commercial electric water heaters

## 1026 MODELS

80 imperial gallons / 364 litres

Model	Storage Capacity		Input (kW)	Voltage (Volts)	Ph.	Dimensions inches (cm)		Weight lb (kg)
	Imp. gal	Litres				H	D	
1026	80	364	18 to 36	208	1-3	55 3/8 (141)	28 1/4 (72)	380 (172)
1026	80	364	18 to 36	240	1-3	55 3/8 (141)	28 1/4 (72)	380 (172)
1026	80	364	18 to 36	600	3	55 3/8 (141)	28 1/4 (72)	380 (172)

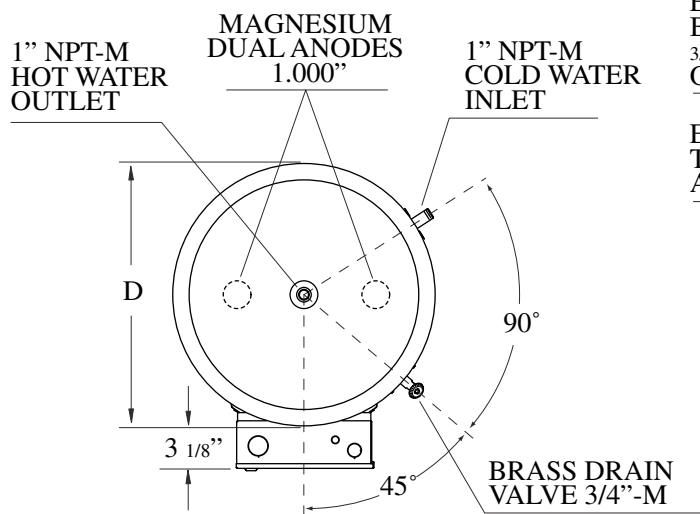

ELECTRICAL BOX WITH 3/4" to 1 1/4" OPENINGS

ELEMENTS AND THERMOSTATS ACCESS DOOR

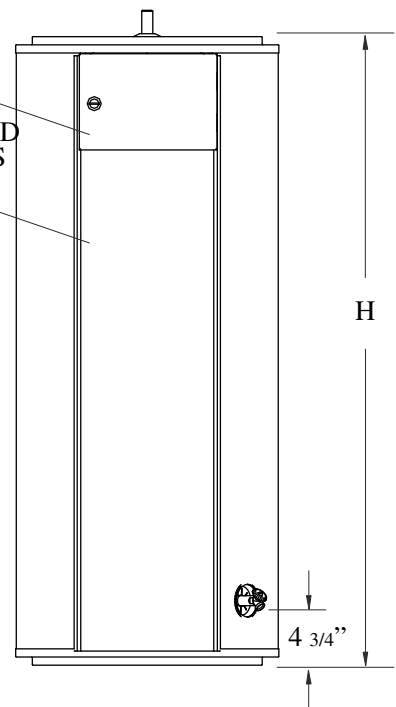

JOB TITLE

ADDRESS

CONTRACTOR

ADDRESS

ENGINEER

SUBMITTED DATE

REQUIRED PRODUCT

MODEL NO. SIZE QUANTITY

MODEL NO. SIZE QUANTITY

MODEL NO. SIZE QUANTITY

MODEL NO. SIZE QUANTITY

REQUIRED DATE

In accordance with our product continued improvement policy, Giant Factories Inc. reserves the right to make changes or improvements at any time without prior notice.

[giantinc.com](http://giantinc.com)