



ENGINEERING SUBMITTAL DATA SHEET

Commercial natural gas-fired flue-tampered water heaters

UG65 MODELS

54 imperial gallons / 65 U.S. gallons
insulated with 2" high density fiberglass

Model	Storage Capacity			Type of gaz	Input Btu	Recovery 100 °F (56 °C)			Altitude	Est. ship. weight lb (kg)
	(US) gal	Litres	Imp. gal			(US) gal	Litres	Imp. gal		
UG65-250NH	65	246	54	N	225,000	213	806	177	N & H	465 (211)
UG65-250N	65	246	54	N	250,000	236	893	197	N	465 (211)
UG65-300NH	65	246	54	N	275,000	255	965	212	N & H	465 (211)
UG65-300N	65	246	54	N	300,000	284	1,075	236	N	465 (211)
UG65-360NH	65	246	54	N	324,000	306	1,158	255	N & H	465 (211)
UG65-360N	65	246	54	N	360,000	340	1,287	283	N	465 (211)

DIMENSIONS inches (cm)

Model	A	B	C	D	E1	E2	E3	E4	F	G	H	I	J	K
UG65	15¾ (40)	52½ (132)	64¾ (164)	6¾ (16)	25¼ (64)	58¼ (148)	25¼ (64)	58¼ (148)	71⅝ (182)	33 (84)	8 (20)	26½ (67)	40.3°	10.9°
UG65-250	15¾ (40)	52½ (132)	64¾ (164)	6¾ (16)	25¼ (64)	58¼ (148)	25¼ (64)	58¼ (148)	70⅞ (180)	33 (84)	7 (17.8)	26½ (67)	40.3°	10.9°

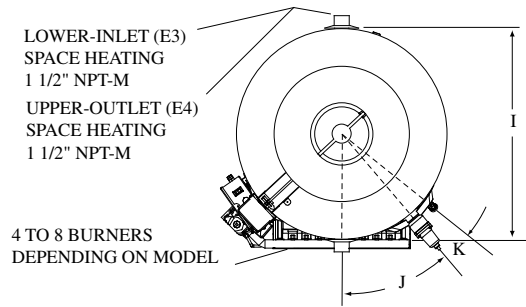
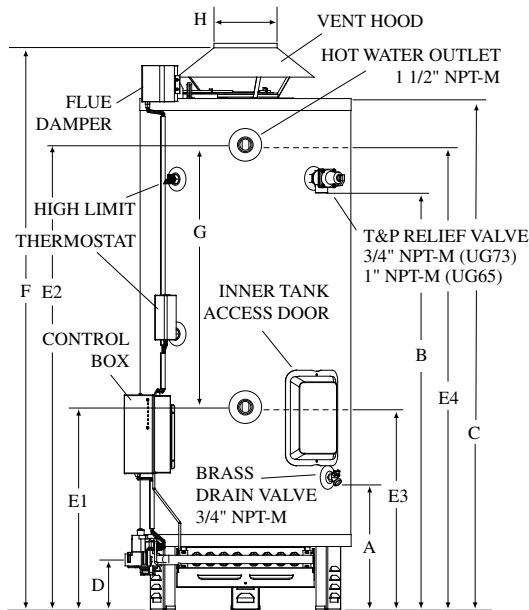

JOB TITLE _____

ADDRESS _____

CONTRACTOR _____

ADDRESS _____

ENGINEER _____

SUBMITTED DATE _____

REQUIRED PRODUCT _____

MODEL NO. _____ SIZE _____ QUANTITY _____

MODEL NO. _____ SIZE _____ QUANTITY _____

MODEL NO. _____ SIZE _____ QUANTITY _____

MODEL NO. _____ SIZE _____ QUANTITY _____

REQUIRED DATE _____

In accordance with our product continued improvement policy, Giant Factories Inc. reserves the right to make changes or improvements at any time without prior notice.

giantinc.com



40 Lesage Avenue, Montreal-East (Quebec) Canada H1B 5H3 • Telephone: (514) 645-8893 • Fax: (514) 640-0969