



# ENGINEERING SUBMITTAL DATA SHEET

Commercial natural gas-fired flue-tampered water heaters

## UG73 MODELS

61 imperial gallons / 73 U.S. gallons  
insulated with 2" high density fiberglass

Model	Storage Capacity			Type of gas	Input Btu	Recovery 100 °F (56 °C)			Altitude	Est. ship. weight lb (kg)
	(US) gal	Litres	Imp. gal			(US) gal	Litres	Imp. gal		
UG73-125NH	73	276	61	N	112,000	106	401	88	N & H	429 (195)
UG73-125N	73	276	61	N	125,000	118	447	98	N	429 (195)
UG73-150NH	73	276	61	N	135,000	128	484	107	N & H	429 (195)
UG73-150N	73	276	61	N	150,000	142	538	118	N	429 (195)
UG73-200NH	73	276	61	N	180,000	170	643	142	N & H	429 (195)
UG73-200N	73	276	61	N	200,000	189	715	157	N	429 (195)

### DIMENSIONS inches (cm)

Model	A	B	C	D	E1	E2	E3	E4	F	G	H	I	J	K
UG73	15 3/4 (40)	52 1/2 (133)	64 3/8 (164)	6 3/8 (16)	25 1/4 (64)	58 1/4 (148)	25 1/4 (64)	58 1/4 (148)	70 7/8 (180)	33 (84)	6 (15)	26 1/2 (67)	40.3°	10.9°
UG73-125	15 3/4 (40)	52 1/2 (133)	64 3/8 (164)	6 3/8 (16)	25 1/4 (64)	58 1/4 (148)	25 1/4 (64)	58 1/4 (148)	69 1/4 (176)	33 (84)	5 (12.7)	26 1/2 (67)	40.3°	10.9°

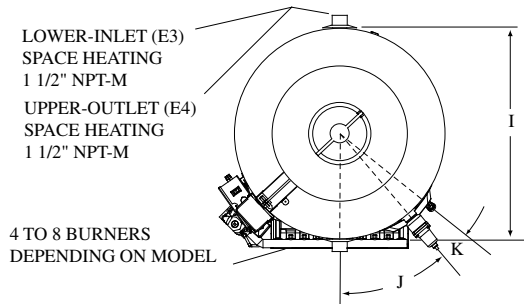
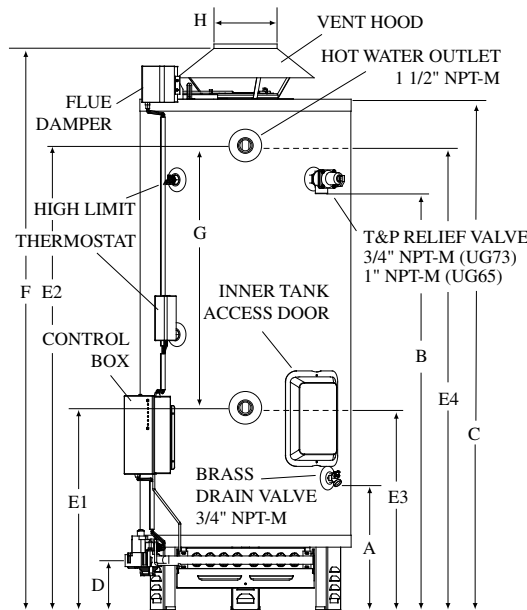

JOB TITLE \_\_\_\_\_

ADDRESS \_\_\_\_\_

CONTRACTOR \_\_\_\_\_

ADDRESS \_\_\_\_\_

ENGINEER \_\_\_\_\_

SUBMITTED DATE \_\_\_\_\_

REQUIRED PRODUCT \_\_\_\_\_

MODEL NO. \_\_\_\_\_ SIZE \_\_\_\_\_ QUANTITY \_\_\_\_\_

MODEL NO. \_\_\_\_\_ SIZE \_\_\_\_\_ QUANTITY \_\_\_\_\_

MODEL NO. \_\_\_\_\_ SIZE \_\_\_\_\_ QUANTITY \_\_\_\_\_

MODEL NO. \_\_\_\_\_ SIZE \_\_\_\_\_ QUANTITY \_\_\_\_\_

REQUIRED DATE \_\_\_\_\_

In accordance with our product continued improvement policy, Giant Factories Inc. reserves the right to make changes or improvements at any time without prior notice.

[giantinc.com](http://giantinc.com)



40 Lesage Avenue, Montreal-East (Quebec) Canada H1B 5H3 • Telephone: (514) 645-8893 • Fax: (514) 640-0969