



# ENGINEERING SUBMITTAL DATA SHEET

## 2" ECO-FRIENDLY INSULATION 75 U.S. GALLONS/62.5 IMPERIAL GALLONS ENERGY EFFICIENT POWER VENTED NATURAL & PROPANE GAS WATER HEATERS UG75 SERIES

Model	Storage capacity			Type of gas	Input Btu	Recovery 90°F/50°C			Altitude	Est. shipping weight	
	U.S. gal	L	Imp. gal			U.S. gal	L	Imp. gal		lb	kg
UG75-64MEPV-P2U	75	284	62.5	LP	63,900	63.9	242	53.2	N&H	335	152
UG75-71MEPV-P2U	75	284	62.5	LP	71,000	71.0	269	59.1	N	335	152
UG75-68MEPV-N2U	75	284	62.5	N	67,500	67.5	256	56.2	N&H	335	152
UG75-75MEPV-N2U	75	284	62.5	N	75,000	75.0	284	62.5	N	335	152

### DIMENSIONS (inches/cm)

Model	A	B	C	D	E	E3	E4	F	G	H	I	J	K
All UG75 PV	11 <sup>3</sup> / <sub>4</sub> /30	54 <sup>1</sup> / <sub>4</sub> /138	62 <sup>3</sup> / <sub>8</sub> /158	17/43	63/160	18 <sup>1</sup> / <sub>8</sub> /48	54 <sup>1</sup> / <sub>4</sub> /138	72 <sup>7</sup> / <sub>8</sub> /184	11/28	26/66	3/8	63.6°	7.8°

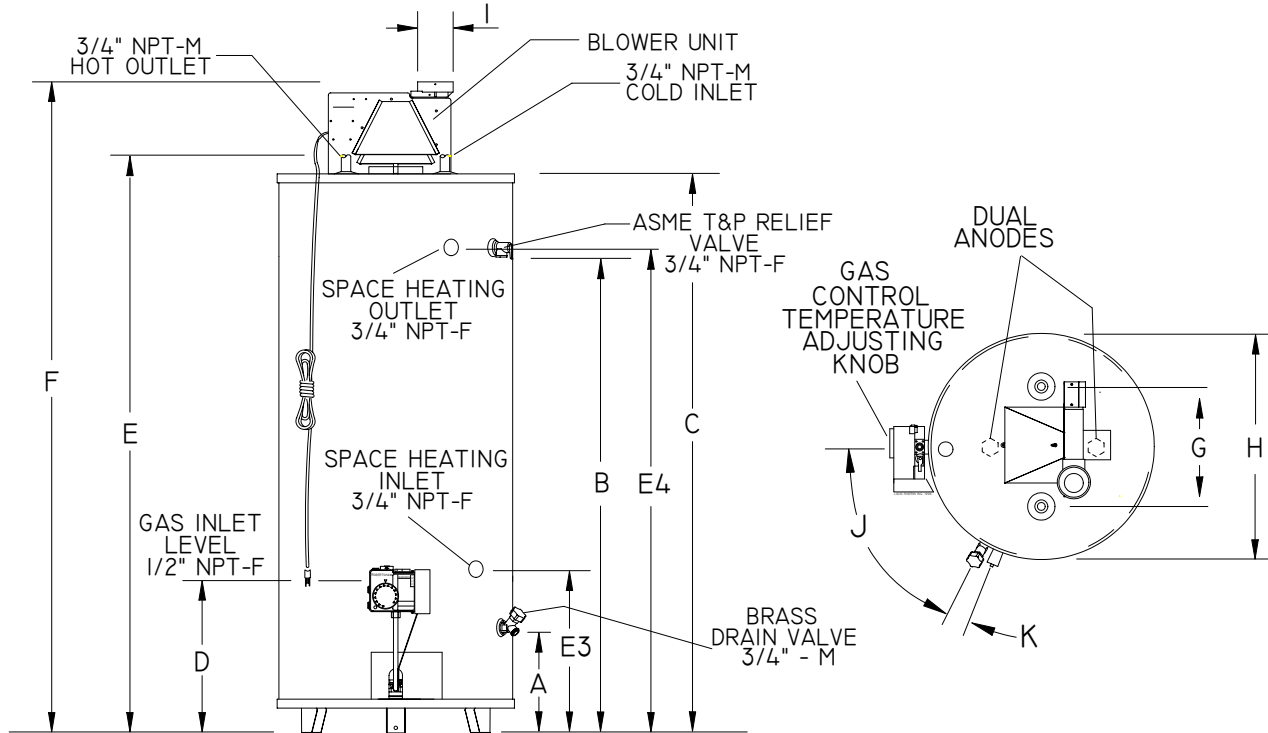

JOB TITLE: \_\_\_\_\_  
 ADDRESS: \_\_\_\_\_  
 \_\_\_\_\_  
 \_\_\_\_\_  
 CONTRACTOR: \_\_\_\_\_  
 ADDRESS: \_\_\_\_\_  
 \_\_\_\_\_  
 \_\_\_\_\_  
 ENGINEER: \_\_\_\_\_

DATE SUBMITTED: \_\_\_\_\_  
 PRODUCT REQUIRED: \_\_\_\_\_  

MODEL NO.	SIZE	QUANTITY
_____	_____	_____
_____	_____	_____
_____	_____	_____
_____	_____	_____

 DATE REQUIRED: \_\_\_\_\_

**Giant Factories Inc.**  
 40 Avenue Lesage, Montreal-East, Quebec, Canada H1B 5H3  
 Telephone: (514) 645-8893 Fax: (514) 640-0969 www.giantinc.com

Giant Factories Inc. reserves the right to make product changes or improvements at any time without notice.