



ENGINEERING SUBMITTAL DATA SHEET

FVIR compliant residential natural & propane gas-fired water heaters

UG60 MODELS

49.9 imperial gallons / 60 U.S. gallons

insulated with 2" eco-friendly **GREENFOAM**

All models meet or exceed NRCAN energy efficiency requirements

Model	Storage Capacity			Type of gas	Input Btu	Recovery 90 °F / 50 °C			E. F. Number	Altitude	Est. ship. weight lb (kg)
	(US) gal	Litres	Imp. gal			(US) gal	Litres	Imp. gal			
UG60-42MF-P2U	60	227	49.9	LP	42,000	44.1	167	36.7	0.57	N & H	193 (88)
UG60-47MF-P2U	60	227	49.9	LP	47,000	44.1	167	36.7	0.57	N	193 (88)
UG60-47MF-N2U	60	227	49.9	N	47,000	48.1	182	40.1	0.56	N & H	193 (88)
UG60-52MF-N2U	60	227	49.9	N	52,000	53.2	201	44.3	0.56	N	193 (88)

DIMENSIONS inches (cm)											
Model	A	B	C	D	E	F	G	H	I	J	K
All UG60	7 1/8 (18)	48 1/4 (123)	56 5/8 (144)	12 1/8 (31)	57 5/8 (146)	60 7/8 (155)	8 (20)	23 1/2 (60)	4 (10)	15.6°	90.0°

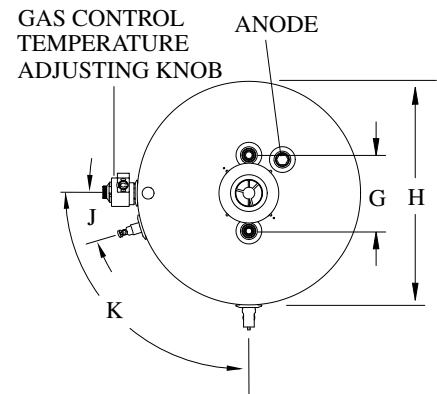
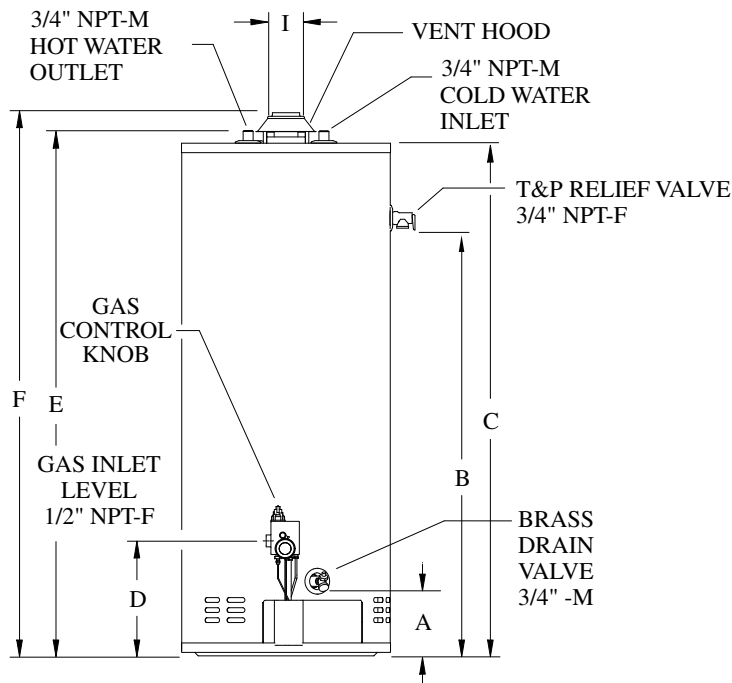

JOB TITLE _____

ADDRESS _____

CONTRACTOR _____

ADDRESS _____

ENGINEER _____

SUBMITTED DATE _____

REQUIRED PRODUCT _____

MODEL NO. _____ SIZE _____ QUANTITY _____

MODEL NO. _____ SIZE _____ QUANTITY _____

MODEL NO. _____ SIZE _____ QUANTITY _____

MODEL NO. _____ SIZE _____ QUANTITY _____

REQUIRED DATE _____

In accordance with our product continued improvement policy, Giant Factories Inc. reserves the right to make changes or improvements at any time without prior notice.

giantinc.com



40 Lesage Avenue, Montreal-East (Quebec) Canada H1B 5H3 • Telephone: (514) 645-8893 • Fax: (514) 640-0969