



ENGINEERING SUBMITTAL DATA SHEET

FVIR compliant residential power direct vent
natural & propane gas-fired water heaters

UG60 MODELS

50 imperial gallons / 60 U.S. gallons

insulated with eco-friendly GREENFOAM

All models meet or exceed NRCAN energy efficiency requirements

Model	Storage Capacity			Type of gas	Input BTU	Recovery 90 °F / 50 °C			E. F. Number	Altitude	Est. ship. weight	
	(US) gal	Litres	Imp. gal			(US) gal	Litres	Imp. gal			lb	(kg)
UG60-38MFPDV-N1U	60	227	50.0	N	38,000	40.4	153	33.7	0.63	N & H	210	(95)
UG60-41MFPDV-P1U	60	227	50.0	LP	41,000	43.6	165	36.3	0.62	N & H	210	(95)

DIMENSIONS inches (cm)

Model	A	B	C	D	E	F	G	H	I	J	K	L
UG60	9 3/8 (24)	50 1/4 (128)	58 5/8 (149)	14 1/4 (36)	60 1/4 (153)	68 1/2 (174)	3 (7.6)	22 (56)	8 (20)	15.0°	90.0°	16 3/8 (42)

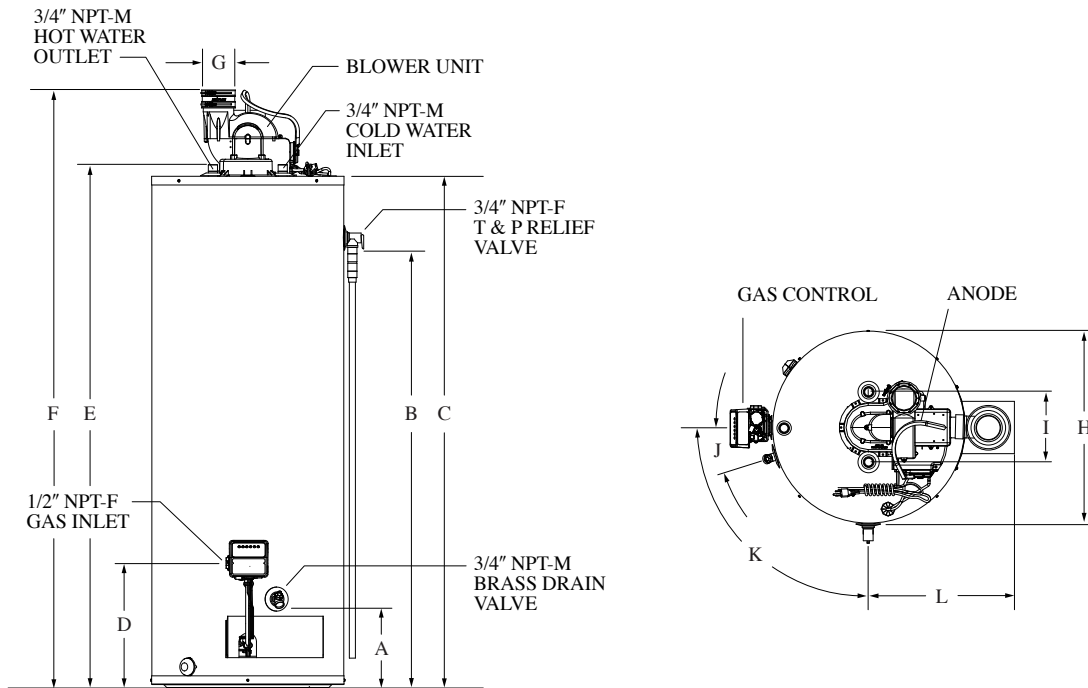

JOB TITLE _____

SUBMITTED DATE _____

ADDRESS _____

REQUIRED PRODUCT _____

CONTRACTOR _____

MODEL NO. _____ SIZE _____ QUANTITY _____

ADDRESS _____

MODEL NO. _____ SIZE _____ QUANTITY _____

ENGINEER _____

MODEL NO. _____ SIZE _____ QUANTITY _____

MODEL NO. _____ SIZE _____ QUANTITY _____

REQUIRED DATE _____

In accordance with our product continued improvement policy, Giant Factories Inc. reserves the right to make changes or improvements at any time without prior notice.

giantinc.com



40 Lesage Avenue, Montreal-East (Quebec) Canada H1B 5H3 • Telephone: (514) 645-8893 • Fax: (514) 640-0969