



Enhancing everyday living



ENGINEERING SUBMITTAL DATA SHEET

Energy efficient Gas Light Duty commercial water heaters

UG75 MODELS

63 imperial gallons / 284 Litres insulated with 2" eco-friendly **GREENFOAM**

These models meet all safety and construction requirements of CSA 4.3 Standard and meet or exceed the thermal efficiency and standby loss requirements of current ASHRAE 90.1 Standard.

Models	Storage Capacity			Type of gas	Input BTU	Recovery 90 °F / 50°C			Altitude	Est. ship. weight lb (kg)
	(US gal)	Litres	Imp. gal			(US gal)	Litres	Imp. gal		
UG75-76MEPV1-N2U	75	284	63	N	76,000	82.9	313.8	69	0 - 7,800	301.1 (136.6)
UG75-76MEPV1-P2U	75	284	63	LP	76,000	83.9	317.6	69.9	0 - 7,800	301.1 (136.6)

DIMENSIONS inches (cm)

Models	A	B	C	D	E	E1	E2	F	G	H	I	J	K	L	M
All UG75	11 ¼ (29)	52 ⅞ (134)	62 ½ (159)	16 ¼ (41)	64 ½ (163)	18 ⅝ (47)	54 ⅛ (137)	72 ¾ (184)	11 (28)	26 (66)	3 (8)	55.8°	63.6°	4 ¾ (12)	2 ¾ (7)

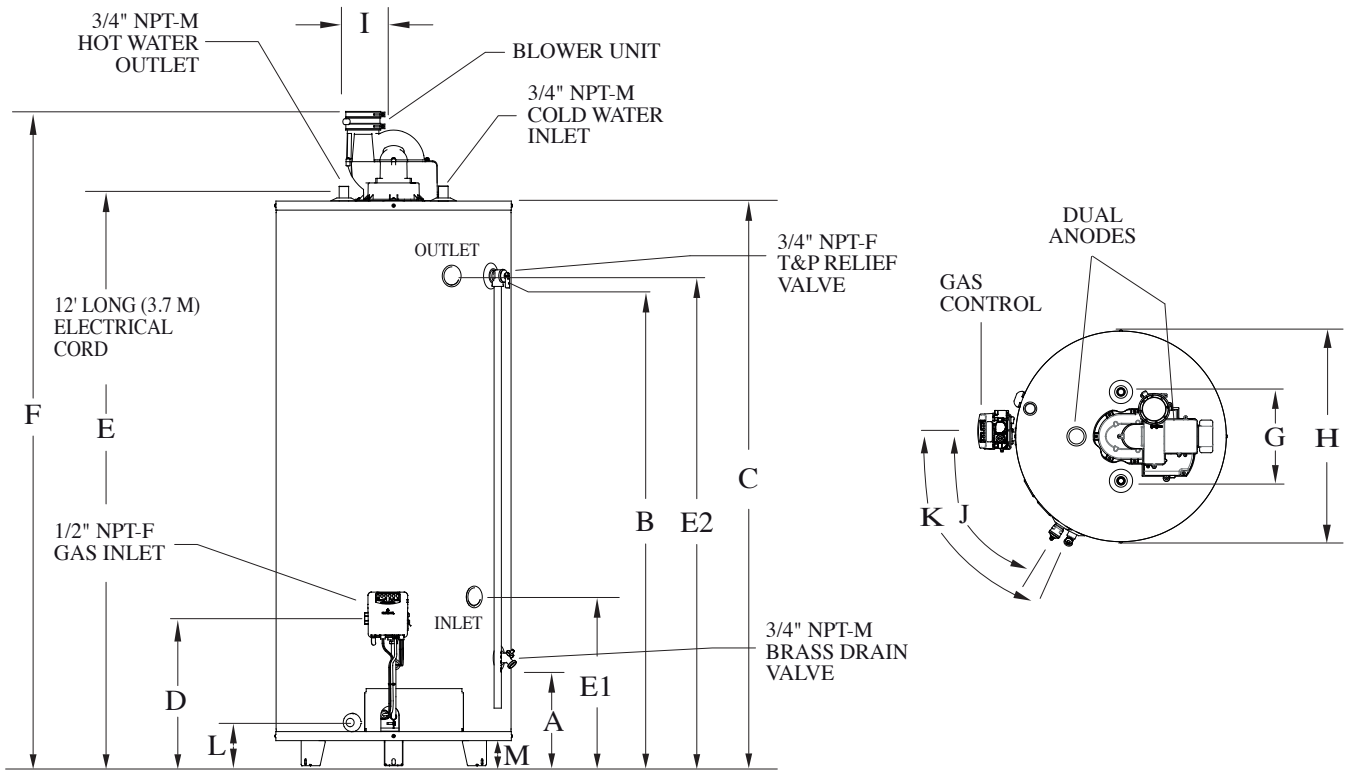

JOB TITLE _____

ADDRESS _____

CONTRACTOR _____

ADDRESS _____

ENGINEER _____

SUBMITTED DATE _____

REQUIRED PRODUCT _____

MODEL NO. _____ SIZE _____ QUANTITY _____

MODEL NO. _____ SIZE _____ QUANTITY _____

MODEL NO. _____ SIZE _____ QUANTITY _____

MODEL NO. _____ SIZE _____ QUANTITY _____

REQUIRED DATE _____

In accordance with our company policy of on-going product improvement, Giant Factories Inc. reserves the right to make changes without prior notice.

giantinc.com



40 Lesage Avenue, Montréal-East (Québec) Canada H1B 5H3 • Telephone: (514) 645-8893 • Fax: (514) 640-0969