

TAKE A *Giant*[®]
STEP FORWARD,
HELP STOP
THE GREENHOUSE
EFFECT



Eco-friendly foam insulation
unique to Giant
No HCFC's
No CFC's
No VOC's



40 Lesage Avenue, Montréal-East, Québec, Canada, H1B 5H3
Telephone: 514 645-8893 • Toll free: 1 (800) 363-9354
General fax: 514 640-0969
Customer Service fax: 514 645-8413

giantinc.com



STORAGE TANKS

Available in
30, 40 & 60 gallon capacities
for residential models
and
80 & 100 gallon capacities
for commercial models

**BUILT
TO LAST
LONGER**



The following outstanding technical features are why these storage tanks are “BUILT TO LAST LONGER”.

INSULATION

A thick uniform blanket of **GREENFOAM** eco-friendly insulation provides our 30, 40, and 60 gallon tanks a heat retention system that reduces stand-by losses and energy costs. Storage tanks of 80 and 100 gallon capacities use high density fiberglass.

INNER TANK

A uniquely formulated blue cobalt glass enriched with zircon is fused to specially treated steel at 1,600°F (871°C) to provide the best coating available against corrosion for many years. The tank is certified at a test pressure of 300 PSI (2,068 kPa) and a working pressure of 150 PSI (1,034 kPa).

ANODE

A unique magnesium anode (AZ31) in excess of CSA standard C309 requirements is provided for rust prevention.

FACTORY INSTALLED 3/4" NPT DI-ELECTRIC NIPPLES

Extend the life of the water heater by providing excellent corrosion protection.

COLD WATER SUPPLY

30, 40 & 60 gal. storage tanks are available in a top entry configuration and are equipped with a brass combination inlet drain valve.

NOTE: Commercial ISO models are insulated with fiberglass, do not come with square flange adapters, are not equipped with a brass combination drain valve, and have different hot and cold water piping connections than the other models. Please refer to the diagram provided.

TEMPERATURE & PRESSURE-RELIEF VALVE

For safety purposes, a temperature & pressure-relief valve **MUST** be included in the installation of all Giant STORAGE tanks. This valve will protect the tank from the damaging effects of excessive temperature and pressure.

WARRANTY

During the warranty period, GIANT will replace a storage tank proven to be defective with an equivalent new storage tank with the exception of transportation and labor costs. Defective components will be replaced with the same conditions.

All models are suitable for potable water and space heating applications. Toxic chemicals, such as those used for boiler treatment, must **NEVER** be introduced into this system. This unit must **NEVER** be connected to any existing heating system or component(s) previously used with a non-potable water heating appliance.

30, 40 & 60 GALLONS INSULATED WITH **GREENFOAM**

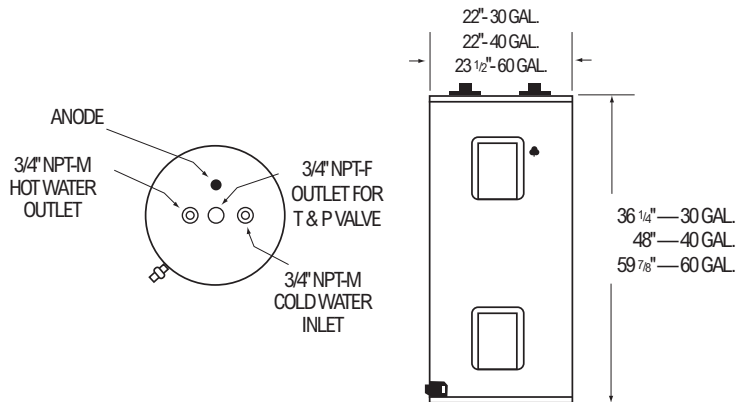

80 & 100 GALLONS NON-INSULATED

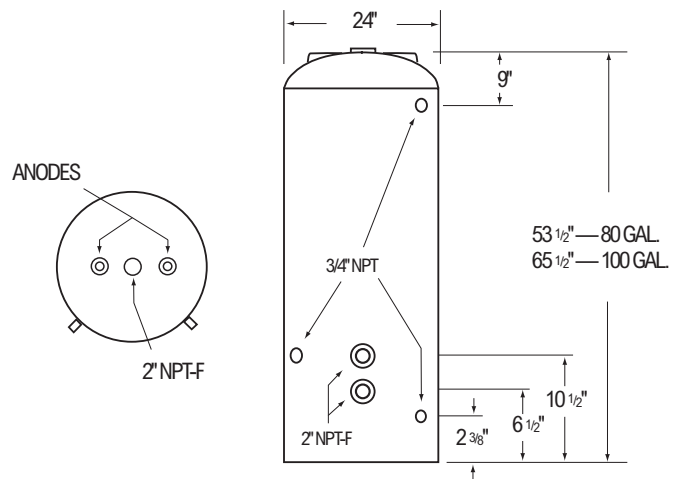

80 & 100 GALLONS INSULATED (HIGH DENSITY FIBERGLASS)

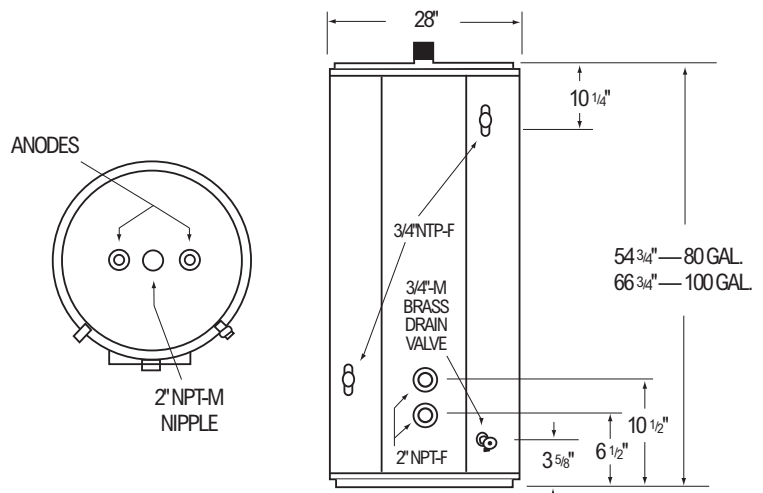

Models	Capacity			Shipping weight lb (kg)
	U.S. gal.	Litre	Imp. gal.	
142ETE-9G7M	34.2	129.6	28.5	115 (52)
152ETE-9G7M	48.6	184	40.5	140 (64)
172ETE-9G7M	74.8	283	62.3	197 (89)
1001 (not insulated)	96	364	80	325 (147)
1000 ISO (Insulated with fiberglass)	96	364	80	370 (168)
1101 (not insulated)	120	454	100	370 (168)
1100 ISO (Insulated with fiberglass)	120	454	100	415 (188)

In accordance with our company policy of on-going product improvement, Giant Factories Inc. reserves the right to make changes without prior notice.