

Giant[®]

PROUDLY CANADIAN 

RESIDENTIAL POINT OF USE ELECTRIC WATER HEATERS

Available in
2, 5, 10, 16 and 22 gallon capacities

**BUILT
TO LAST
LONGER**



The following outstanding technical features are why these residential point of use electric water heaters are “BUILT TO LAST LONGER”.

POINT OF USE MODELS

- HIGH DENSITY FIBERGLASS INSULATION**
 Provides superior heat retention and efficiency while being environmentally friendly.
- FACTORY INSTALLED 3/4" NPT DI-ELECTRIC NIPPLES**
 Extend the life of the water heater by providing excellent corrosion protection.
- HIGH QUALITY MAGNESIUM ANODE**
 Provides excellent protection against the corrosive effects of water and extends tank life.
- ELECTRIC ELEMENTS**
 All models are equipped with CSA approved screw-in type immersion elements made by Giant. These elements can be easily replaced with no special tools, resulting in low maintenance costs.
- GLASS LINED INNER TANK**
 A uniquely formulated blue cobalt glass enriched with zircon is fused to specially treated steel at 1,600°F (871°C) to provide the best coating available against corrosion for many years. The tank is certified at a test pressure of 300 PSI (2,068 kPa) and a working pressure of 150 PSI (1,034 kPa).
- AUTOMATIC TEMPERATURE CONTROL**
 Adjustable thermostat will provide years of reliable trouble-free service at the desired water temperature and a safety cut-off is provided for abnormal conditions.
- FACTORY INSTALLED T&P RELIEF VALVE**
 Protects the tank from the damaging effects of excessive temperature and pressure.
- WARRANTY**
 Giant residential point of use electric water heaters have a six (6) year limited warranty against inner tank leakage from the date of installation and one (1) year limited warranty on component parts. For more specific warranty details including exceptions, consult the owner's manual that is provided with each water heater.



40 Lesage Avenue, Montréal-East, Québec, Canada, H1B 5H3
 Telephone: (514) 645-8893 • Toll free: 1 (800) 363-9354
 General Fax: (514) 640-0969
 Customer Service Fax: (514) 645-8413

giantinc.com

In accordance with our company policy of on-going product improvement, Giant Factories Inc. reserves the right to make changes without prior notice.

103ETE Model

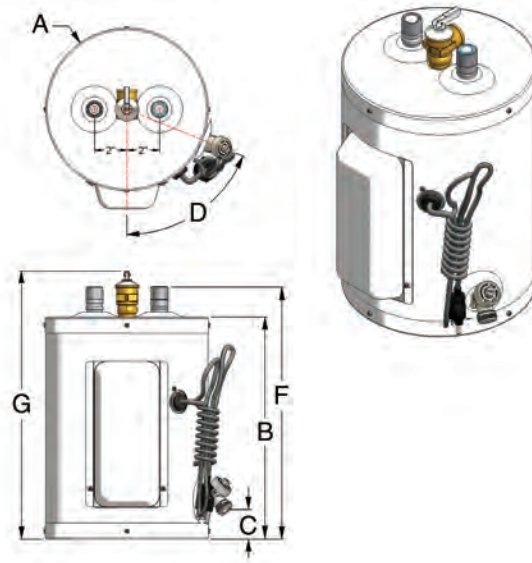

106, 112, 119 & 130SEO Models

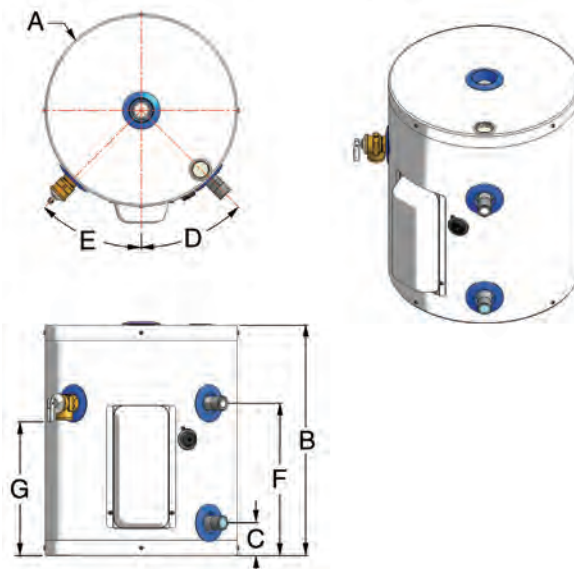

SPECIFICATIONS & DIMENSIONS

Model	Storage capacity			Factory installed wattages						Diameter (A) inches (cm)		Height (B) inches (cm)		C inches (cm)	D	E	F inches (cm)		G inches (cm)		Estimated ship. weight lb (kg)	
				120V		208V		240V														
	U.S. gal.	Litre	Imp. gal.	Watt	Amp.	Watt	Amp.	Watt	Amp.													
103ETE	2.4	9	2	1,500	12.50	---	---	---	---	10 (25)	13 3/4 (35)	1 1/2 (4)	68°	—	15 5/8 (40)	16 1/2 (42)	24	(11)				
106SEO	6	23	5	1,500	12.50	2,250	10.8	3,000	12.50	14 (36)	16 7/8 (43)	2 3/8 (6)	45°	45°	11 1/8 (28)	9 3/4 (25)	37	(17)				
112SEO	12	45	10	1,500	12.50	2,250	10.8	3,000	12.50	16 (41)	22 1/4 (57)	2 1/2 (6)	45°	45°	16 1/2 (42)	15 1/2 (40)	55	(25)				
119SEO	19	72	16	1,500	12.50	2,250	10.8	3,000	12.50	18 1/4 (46)	26 1/2 (67)	2 3/8 (6)	45°	45°	20 3/8 (52)	19 (48)	71	(32)				
130SEO	26	100	22	1,500	12.50	2,250	10.8	3,000	12.50	21 7/8 (56)	31 (79)	2 3/8 (6)	45°	45°	23 7/8 (61)	22 1/2 (57)	90	(41)				